

通信机用陶瓷滤波器 Ceramic Filter for Communication

主要参数 PRINCIPAL PARAMETERS

型号 Part No.	6分贝带宽 6dB Band Width (kHz)min	选择性 Selectivity		阻带衰减 Stop Band Att $f_0 \pm 100\text{kHz}$ (dB)min	插入损耗 Insertion Loss (dB)max	输入/输出阻抗 In/Output Impedance (k Ω)
		衰减带宽 Att Band Width (kHz)max	保证衰减量 Att Specified (dB)min			
LT455BW	± 15	± 30	50	40	4	1.5
LT455CW	± 12.5	± 24				
LT455DW	± 10	± 20				
LT455EW	± 7.5	± 15				
LT455FW	± 6	± 12.5		60	6	2
LT455GW	± 4.5	± 10				
LT455HW	± 3	± 9				
LT455IW	± 2	± 7.5				
LTW455HT	± 3	± 9				
LTW455IT	± 2	± 7.5				

注：中心频率 (f_0) 也有450kHz的
也有LTS455、450型的

Also available with center frequency(f_0)of 450kHz
Also available with LTS455、450

外形尺寸 DIMENSIONS

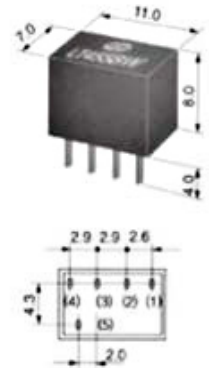

- 1: 输入 Input
 - 2,3,4: 接地 Ground
 - 5: 输出 Output
- (单位: mm) (Unit: mm)

主要参数 PRINCIPAL PARAMETERS

型号 Part No.	6分贝带宽 6dB Band Width (kHz)min	选择性 Selectivity		阻带衰减 Stop Band Att $f_0 \pm 100\text{kHz}$ (dB)min	插入损耗 Insertion Loss (dB)max	输入/输出阻抗 In/Output Impedance (k Ω)
		衰减带宽 Att Band Width (kHz)max	保证衰减量 Att Specified (dB)min			
LT370DW	± 10	± 20	50	40	4	1.5
LT410GW	± 4.5	± 10	50	40	6	2

注：中心频率 (f_0) 也有450kHz的
也有LTS455、450型的

Also available with center frequency(f_0)of 450kHz
Also available with LTS455、450

外形尺寸 DIMENSIONS

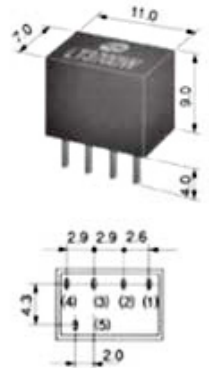

- 1: 输入 Input
 - 2,3,4: 接地 Ground
 - 5: 输出 Output
- (单位: mm) (Unit: mm)

LT455□W测量线路 TEST CIRCUIT

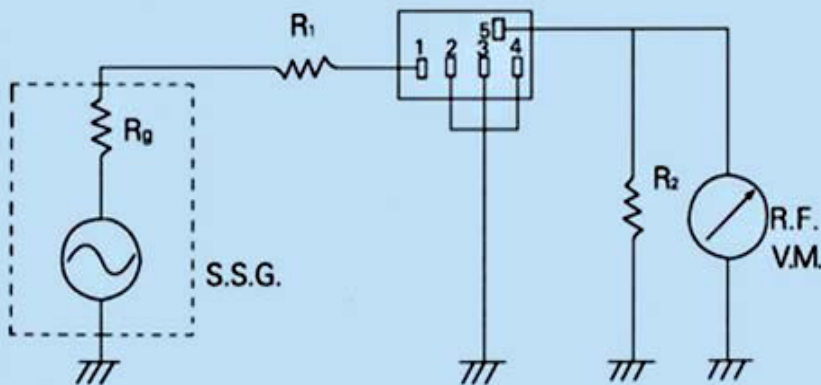

- $R_0 + R_1 = R_2$ = 输入/输出阻抗
 $R_0 + R_1 = R_2$ = Input/Output Impedance